



HEWLETT-PACKARD COMPANY / OPERATING AND SERVICE MANUAL

**526B**

**TIME INTERVAL UNIT**

# OPERATING AND SERVICING MANUAL



## MODEL 526B TIME INTERVAL UNIT

SERIALS PREFIXED: 024 -

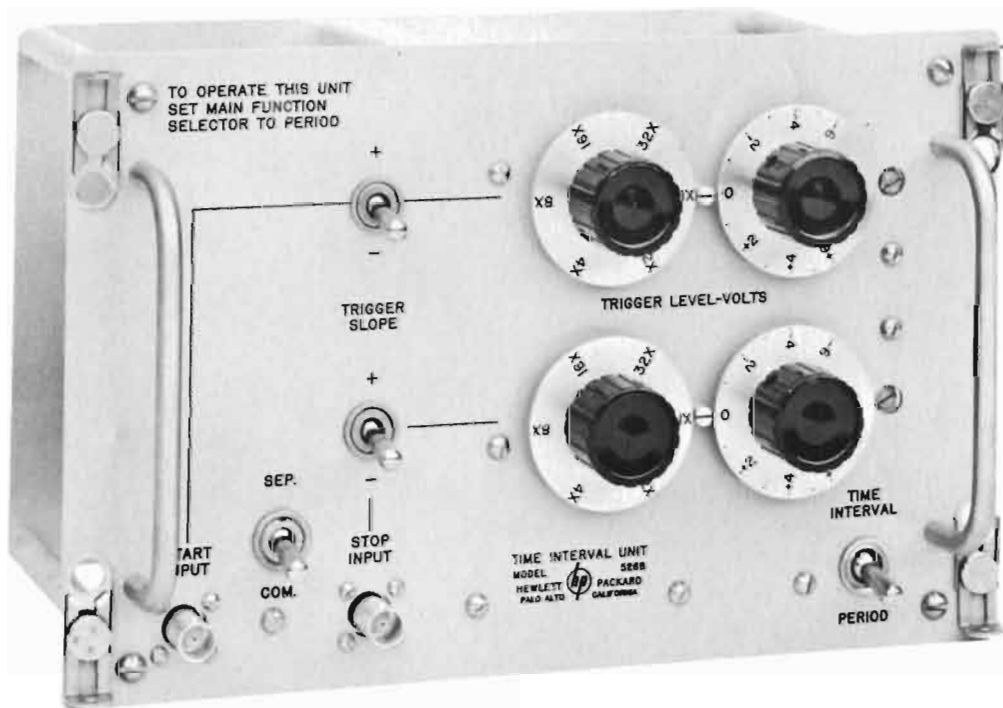

## SPECIFICATIONS

(PLUGGED INTO 524B, C, or D ELECTRONIC COUNTER)

RANGE:	1 $\mu$ sec to $10^7$ seconds.
ACCURACY:	$\pm 1$ period of standard frequency counted, $\pm$ time base accuracy.
REGISTRATION:	On 524 Counter
INPUT VOLTAGE:	1 volt peak minimum, direct-coupled input.
INPUT IMPEDANCE:	Approximately 1 megohm, 40 pf shunt.
START STOP:	Independent or common channels.
TRIGGER SLOPE:	Positive or negative on start and/or stop channels.
TRIGGER AMPLITUDE:	Both channels continuously adjustable from -192 to +192 volts.
STANDARD FREQUENCY COUNTED:	10 cps; 1 kc, 100 kc; 10 mc from 524; externally applied frequency.
READS IN:	Seconds, milliseconds, or microseconds; decimal point automatically positioned.
ACCESSORIES FURNISHED:	AC-16K Cable Assembly, 42' RG-58/U cable terminated on one end with UG-88/U BNC Connector.
ACCESSORIES AVAILABLE	525A-45A Transit Case, with carrying handle.
WEIGHT:	Net 5 lbs., Shipping 8 lbs.

## CONTENTS

SECTION I	GENERAL DESCRIPTION	Page
1 - 1	Introduction . . . . .	I - 1
1 - 2	Damage in Transit . . . . .	I - 1
SECTION II	OPERATING INSTRUCTIONS	
2 - 1	Controls . . . . .	II - 1
2 - 2	Setting the Trigger Level-Volts Controls . . . . .	II - 1
SECTION III	CIRCUIT DESCRIPTION	
3 - 1	General . . . . .	III - 1
3 - 2	Circuit Detail . . . . .	III - 1
SECTION IV	MAINTENANCE	
4 - 1	General . . . . .	IV - 1
4 - 2	Adjusting the Trigger Level-Volts Controls . . . . .	IV - 1
SECTION V	REPLACEABLE PARTS	
5 - 1	Introduction . . . . .	V - 1
5 - 2	Table of Replaceable Parts . . . . .	V - 1
5 - 3	Ordering Information . . . . .	V - 1

# SECTION I GENERAL DESCRIPTION

## 1-1 INTRODUCTION

The Model 526B Time Interval Unit converts an 524B, C, or D Electronic Counter into an accurate time measuring instrument. This instrument measures pulse width, pulse delay, or time between nearly any two electrical events, with a resolution of 0.1 microsecond. Separate input channels are

provided so start and stop signals may be from unrelated sources.

## 1-2 DAMAGE IN TRANSIT

Thoroughly inspect this instrument upon receipt. If there is any damage, see "Claim for Damage in Shipment" paragraph at the rear of this manual.

# SECTION II

## OPERATING INSTRUCTIONS

### 2-1 CONTROLS

The 526B has two independent channels which determine limits of a time interval. Each has its own controls. The TRIGGER LEVEL-VOLTS controls determine the voltage level a signal must cross to start or stop a measurement. TRIGGER SLOPE controls determine the slope a signal must have, as it crosses the voltage level set by TRIGGER LEVEL-VOLTS controls, to start or stop a measurement. If start and stop signals come from the same source, you may connect START INPUT and STOP INPUT connectors together with the COM-SEP switch and apply the signal to either. However, you must still adjust each channel separately.

### 2-2 SETTING THE TRIGGER LEVEL-VOLTS CONTROLS

The TRIGGER LEVEL-VOLTS controls are approximately calibrated, but in some applications you will have to take special precautions in order to obtain the desired interval. If you use a sharp pulse like that shown in Figure 2-1, there will be little difference whether measurement begins at point A

or B. However, to measure interval "x" of Figure 2-2, you must be more careful. Set TRIGGER LEVEL-VOLTS controls near zero as a preliminary adjustment. Adjust the START and then the STOP controls. Watch for definite changes in measured time. Thus you know that start and stop voltage levels are above the step and that the indicated time interval is actually "x".

It is desirable to examine both start and stop signals on an oscilloscope before attempting a measurement. In this way you can determine whether spurious signals exist, and you will know how carefully you must set the TRIGGER LEVEL-VOLTS controls.

The input circuits in the Time Interval Unit are direct coupled. You can sometimes simplify the setting of the TRIGGER LEVEL-VOLTS controls by eliminating any dc component of the start and/or stop signals with blocking capacitors. However, to avoid drawing grid current and resulting dc shift in the input stages, be sure that peak voltages applied to the input circuits do not exceed ten times the multiplying factor of the coarse TRIGGER LEVEL-VOLTS controls. Either use a higher multiplying factor or externally attenuate the signal.

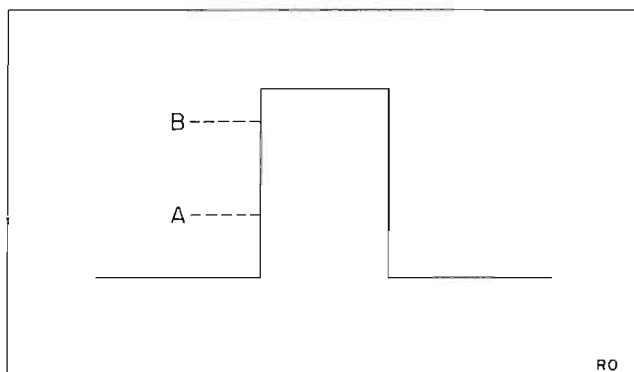

Figure 2-1. Simple Waveform

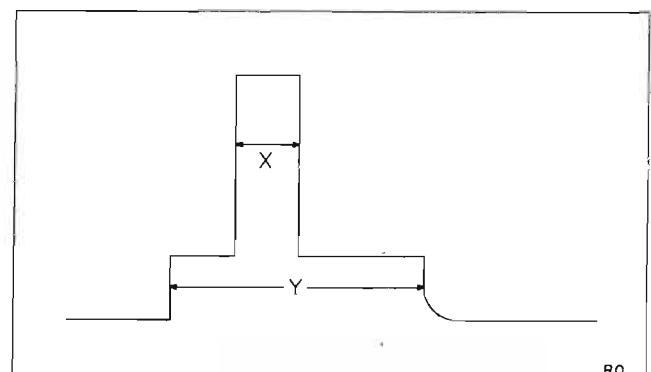

Figure 2-2. Complex Waveform



# SECTION III

## CIRCUIT DESCRIPTION

### 3-1 GENERAL

The 526B sends two negative pulses, start pulse and stop pulse, to a basic counter for each time interval measurement. The start pulse opens a signal gate<sup>1</sup> within the counter, which then counts one of its internal frequencies until the stop pulse closes the signal gate.

### 3-2 CIRCUIT DETAIL

The pulses are generated in two identical circuits. See Figure 3-1. A signal applied to the START INPUT connector is attenuated according to the setting of the coarse TRIGGER LEVEL-VOLTS control. The fine TRIGGER LEVEL-VOLTS control determines the voltage levels required at the input of the stabilized amplifier to actuate the Schmitt trigger.<sup>1</sup>

The circuits of the 526B are dc-coupled; thus slowly varying voltages as well as rapidly varying voltages will actuate the Schmitt trigger. The output of the Schmitt trigger is a step function, negative for a negative-going voltage at the START INPUT connector, positive for a positive-going voltage at the START INPUT connector. L101 shapes the step functions into pulses at one terminal and into inverted pulses at the other terminal. The TRIGGER SLOPE switch selects the terminal of L101 which delivers a negative pulse for the desired slope of the input. The stop circuit operation is exactly the same.

For a measurement between two points on a single waveform, the COM-SEP switch can connect the two input connectors together. Thus the one waveform, connected to either connector, will drive both circuits.

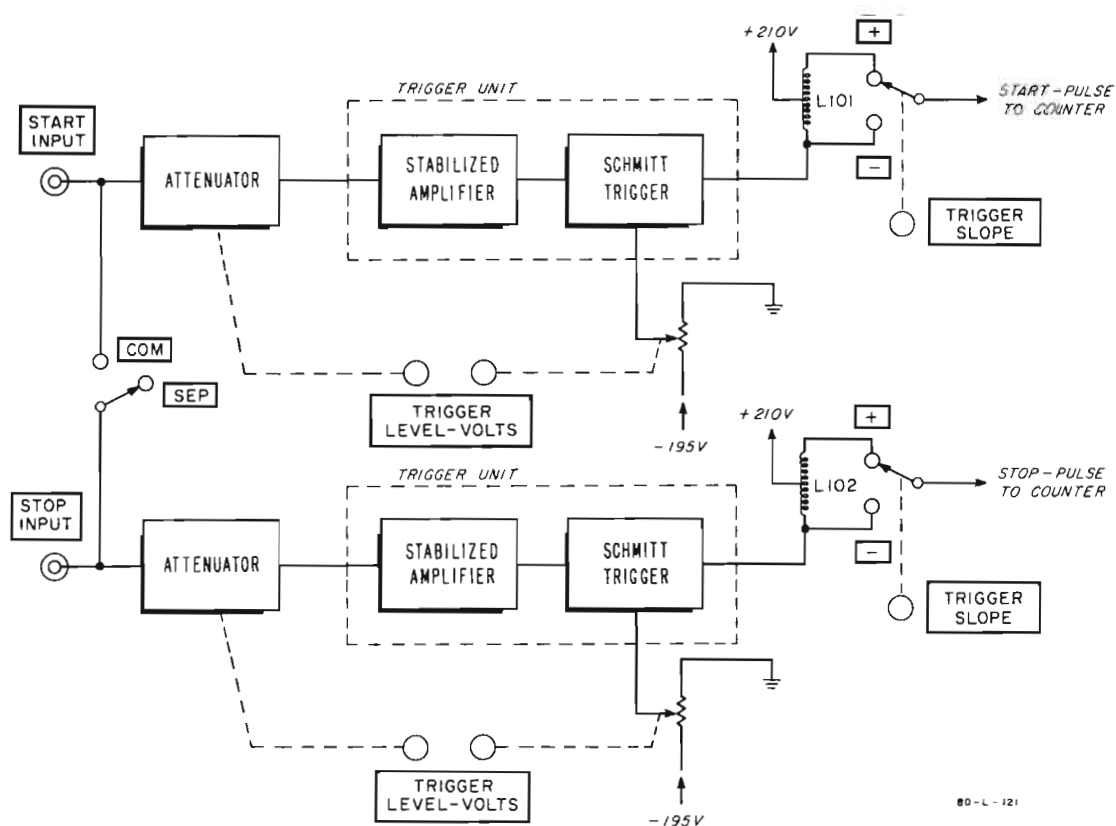

Figure 3-1. 526B Block Diagram

<sup>1</sup> Millman and Taub: "Pulse and Digital Circuits", McGraw-Hill Book Company, Inc., New York, 1956, Sec. 5-10.

Change, et al: "Waveforms", Radiation Laboratory Series, Volume 19, McGraw-Hill Book Company, Inc., New York, 1949, Sec. 5-4.



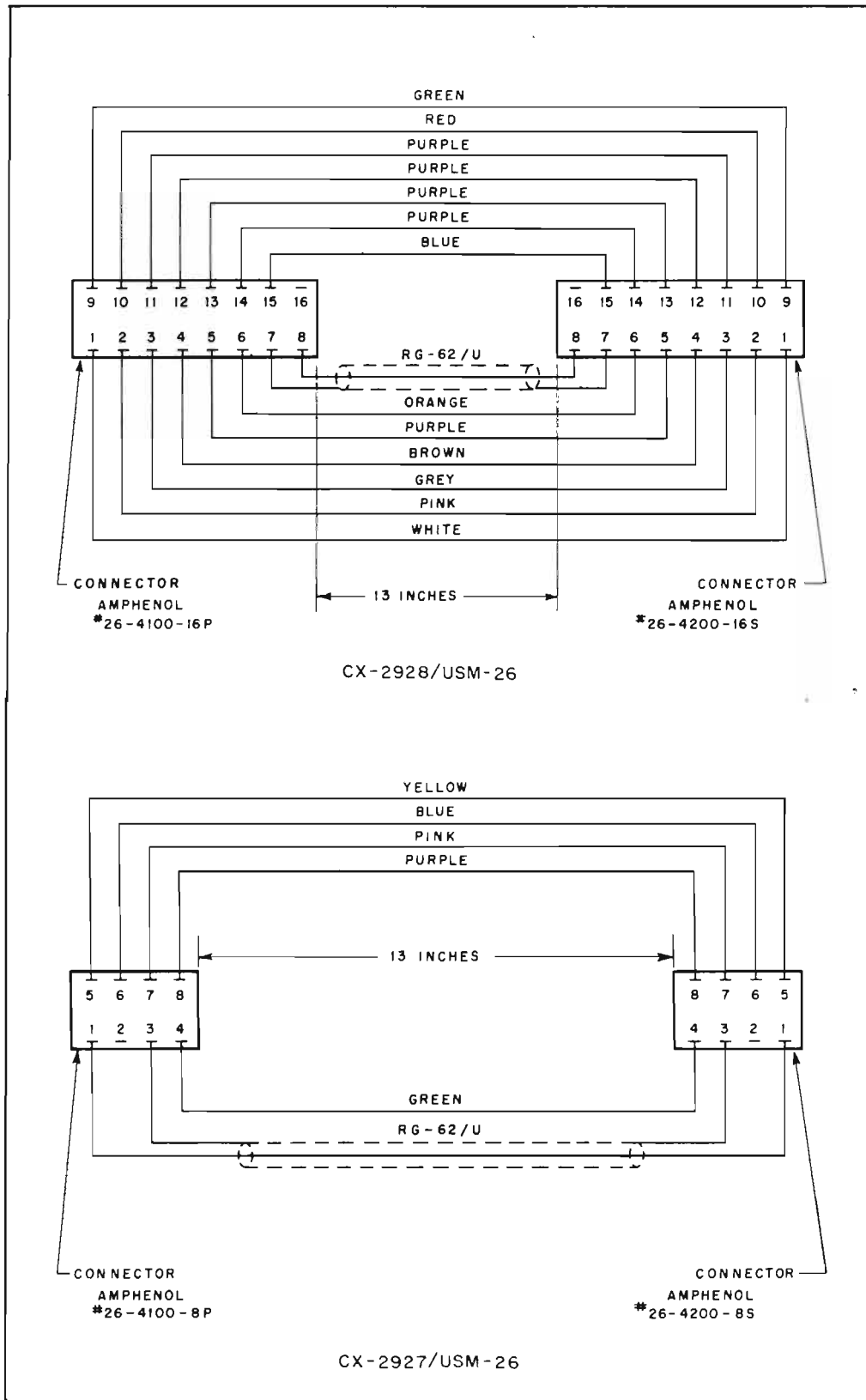

Figure 4-1. Fabrication Data for Test Cables

# SECTION IV MAINTENANCE

## 4-1 GENERAL

The start and stop channels of the 526B are independent units and a trouble in one will generally not affect the other. You can interchange trigger units to isolate trouble in a faulty channel to its trigger unit or other circuitry.

Two cables are available which enable you to test the 526B when it is removed from the counter. Fabrication data for the cables is given in Figure 4-1. You can order the cables from the Hewlett-Packard Company under stock numbers 524B-16Q (8-connector) and 524B-16P (16-connector).

## 4-2 ADJUSTING THE TRIGGER LEVEL-VOLTS CONTROLS

Calibrate TRIGGER LEVEL-VOLTS controls whenever you replace a tube or component in a trigger unit. Proceed as follows:

- a. Plug 526B into counter. Be sure counter power switch is off whenever you install or remove plug-in units. Allow about five minutes warm up.
- b. Set FUNCTION SELECTOR to PERIOD.
- c. Set TIME UNIT switch to 10 MC.
- d. Set TIME INTERVAL-PERIOD switch on 526B to TIME INTERVAL.
- e. Set SEP. COM. switch to COM.
- f. Set both TRIGGER SLOPE switches to same polarity.
- g. Set coarse TRIGGER LEVEL-VOLTS controls to XI.
- h. Set fine TRIGGER LEVEL-VOLTS controls to 0.
- i. Connect a 1 kc sinewave, about 1 V rms, to START INPUT or STOP INPUT connector.
- j. Rotate start channel fine TRIGGER LEVEL-VOLTS control toward +6. Note reading at which measurements stop.
- k. Return control to zero and rotate it toward -6. Note reading at which measurements stop.
- l. Adjust R119, located just to the right of start TRIGGER LEVEL-VOLTS controls, until readings noted in steps j and k are located symmetrically about zero. Return TRIGGER LEVEL-VOLTS control to zero.
- m. Rotate stop channel fine TRIGGER LEVEL-VOLTS control toward +6. Note reading at which stop channel no longer ends the count.
- n. Return control to zero and rotate it toward -6. Note reading at which stop channel no longer ends count.
- o. Adjust R107, located just to right of stop TRIGGER LEVEL-VOLTS controls, until readings noted in steps m and n are located symmetrically about zero.

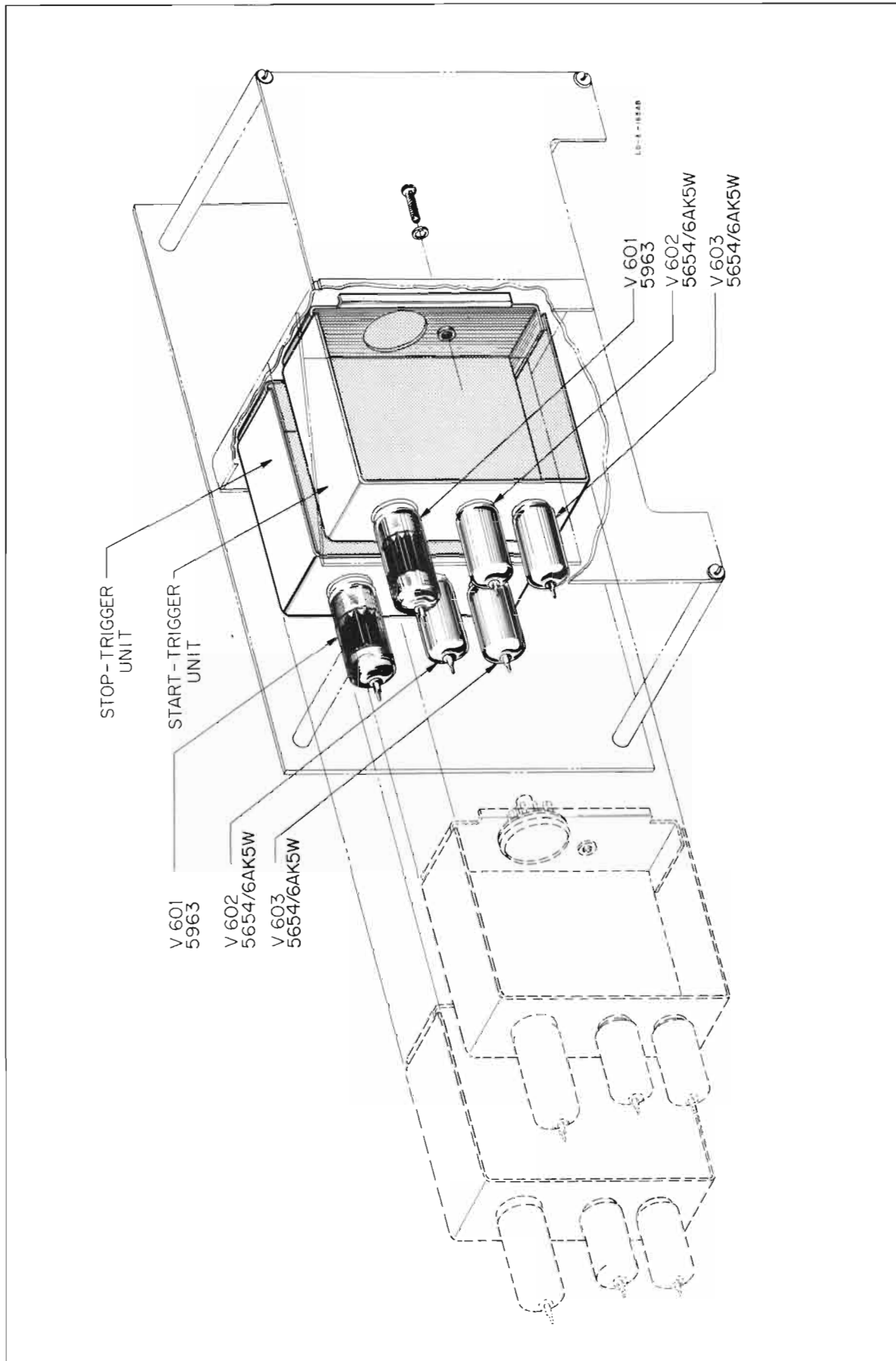
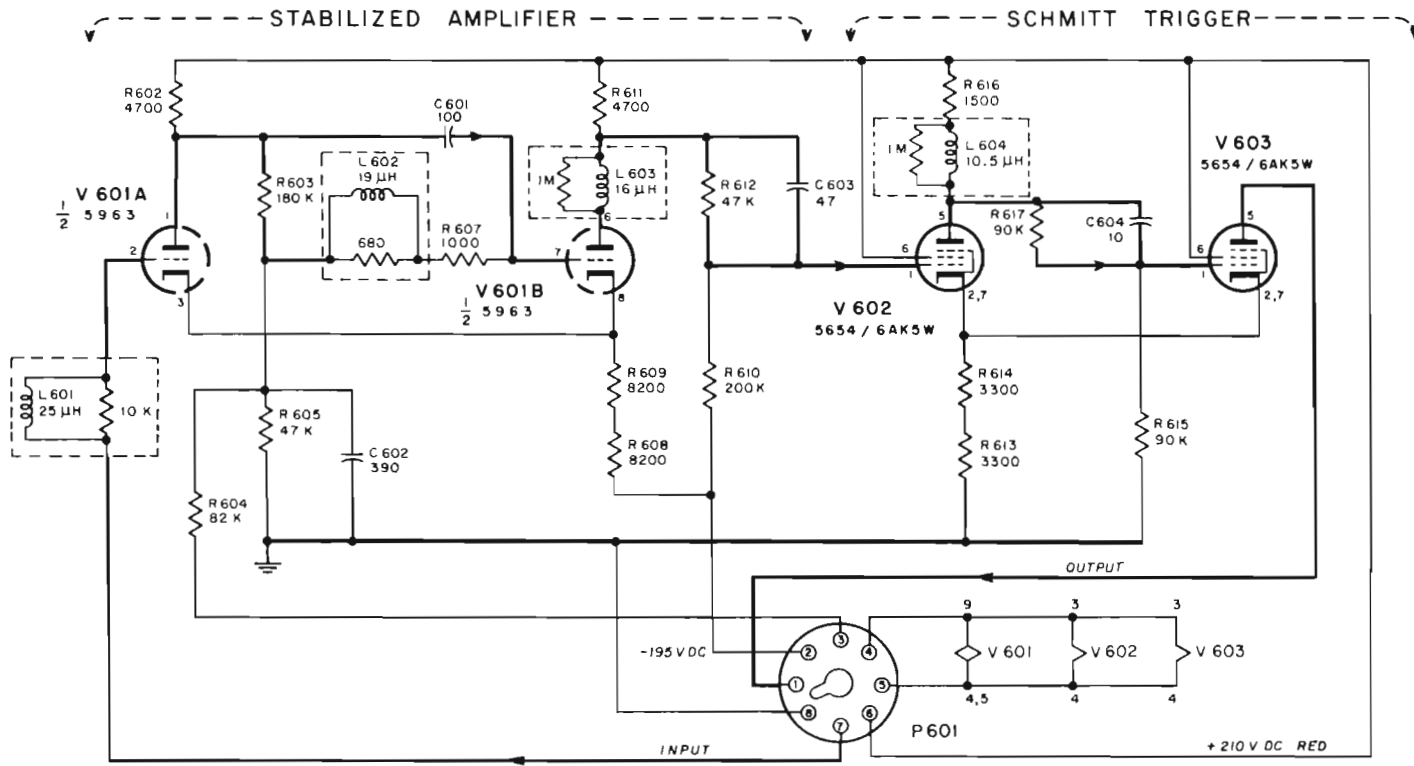

Figure 4-2. Tube Locations



NOTES:  
 ALL RESISTOR VALUES IN OHMS. CAPACITY  
 VALUES IN MICRO-MICROFARADS.  
 K = 1000 M = MEGOHMS  $\perp$  = GROUND

COPYRIGHT 1958 BY HEWLETT-PACKARD COMPANY

This drawing is intended for the operation and maintenance of Hewlett-Packard equipment and is not to be used otherwise or reproduced without written consent of the Hewlett-Packard Company.  
 526B-58B - SCHEM. TRIG. UNIT - T-024A

Figure 4-3. Trigger Unit 526B-58B

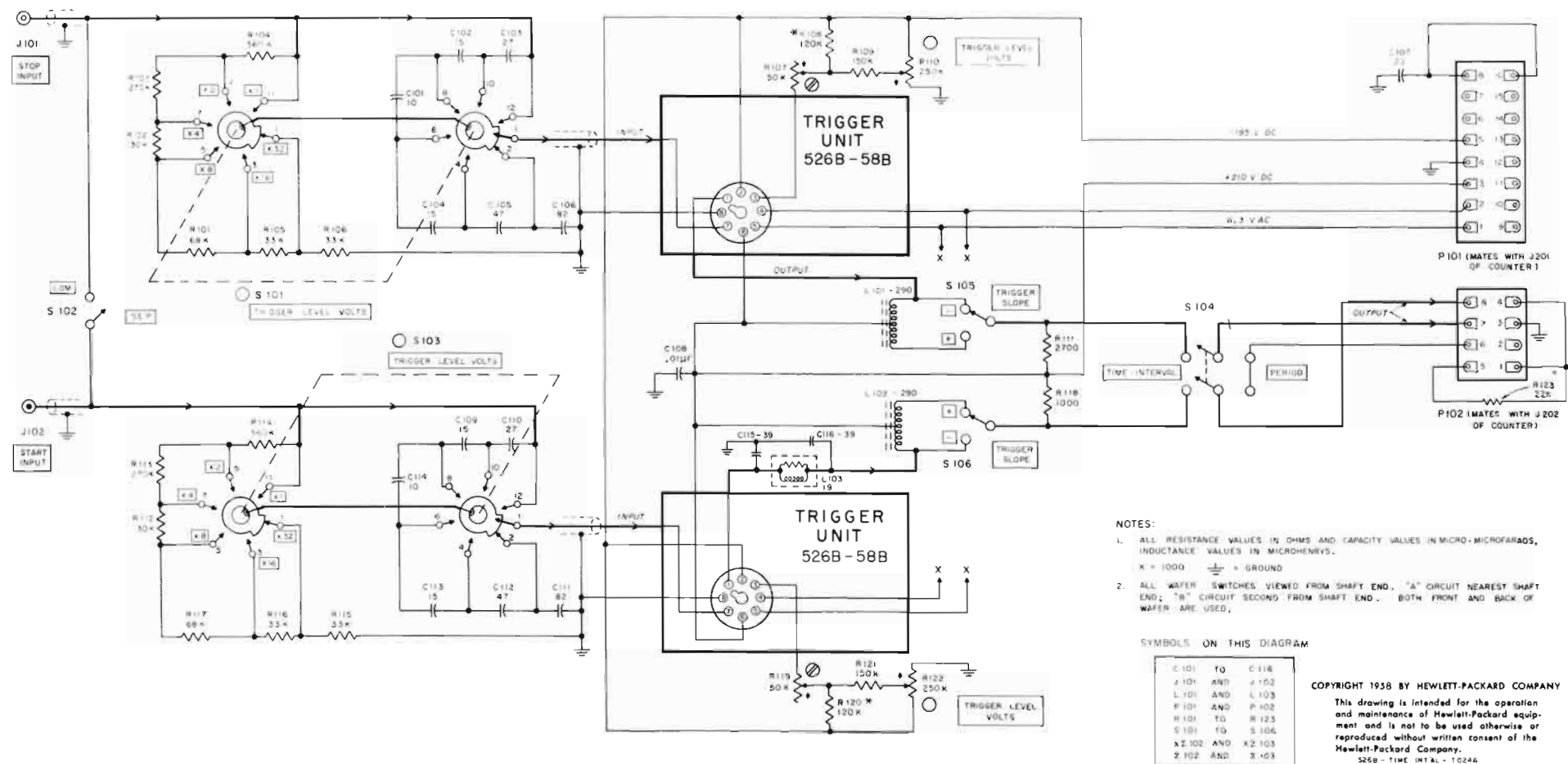

Figure 4-4. Time Interval Unit Model 526B

00038-2

# SECTION V REPLACEABLE PARTS

## 5-1 INTRODUCTION

This section contains information for ordering replacement parts for the 526B Time Interval Unit.

## 5-2 TABLE OF REPLACEABLE PARTS

Table 5-1 lists replaceable parts in alpha-numerical order of their reference designators. At the end of the table are listed miscellaneous items such as knobs which have no assigned reference designators.

Detailed information on a part used more than once in the instrument is listed opposite the first reference designator applying to the part to appear in the table. Other reference designators applying to the same part reference the initial designator. The detailed information includes the following:

- a. Full description of the part.
- b. Manufacturer of the part in a five-digit code -- see list of manufacturers in appendix.
- c. Total quantity used in the instrument (TQ column).
- d. Recommended spare quantity for complete maintenance during one year of isolated service (RS col.).

## 5-3 ORDERING INFORMATION

To order a replacement part, address order or inquiry either to your authorized Hewlett-Packard sales office or to

CUSTOMER SERVICE  
Hewlett-Packard Company  
395 Page Mill Road  
Palo Alto, California

or, in western Europe, to

Hewlett-Packard S. A.  
Rue du Vieux Billard No. 1  
Geneva, Switzerland

Specify the following information on a part:

- a. Model and serial number of the instrument. Be sure to include the three-digit serial prefix.
- b.  $\Phi$  stock number.
- c. Circuit reference designator.
- d. Description.

To order a part not listed in table 5-1, give a complete description of the part including its function and location in the circuit.

Table 5-1. Replaceable Parts (Sheet 1 of 5)

Ckt Ref.	Description	Mfr *	$\Phi$ Stock No.	TQ*	RS*	
	<b>MODEL 526B TIME INTERVAL UNIT</b>					
C1 thru C100	Not assigned					
C101	Capacitor: fixed, mica, 10 pf $\pm 10\%$ , 500 vdcw	76433	0140-0002	2	1	
C102	Capacitor: fixed, mica, 15 pf $\pm 10\%$ , 500 vdcw	76433	0140-0004	4	1	
C103	Capacitor: fixed, mica, 27 pf $\pm 10\%$ , 500 vdcw	00853	0140-0005	2	1	
C104	Same as C102					
C105	Capacitor: fixed, mica, 47 pf $\pm 10\%$ , 500 vdcw	76433	0140-0032	3	1	

\* See introduction to this section

Table 5-1. Replaceable Parts (Sheet 2 of 5)

Ckt Ref.	Description	Mfr *	Stock No.	TQ*	RS*		
C106	Capacitor: fixed, mica, 82 pf $\pm 10\%$ , 500 vdcw	76433	0140-0006	2	1		
C107	Capacitor: fixed, mica, 22 pf $\pm 5\%$ , 300 vdcw	76433	0140-0034	1	1		
C108	Capacitor: fixed, ceramic, .01 $\mu$ f $\pm 20\%$ , 1000 vdcw	01121	0150-0012	1	1		
C109	Same as C102						
C110	Same as C103						
C111	Same as C106						
C112	Same as C105						
C113	Same as C102						
C114	Same as C101						
C115, 116	Capacitor: fixed, mica, 39 pf $\pm 10\%$ , 500 vdcw	00853	0140-0021	2	1		
C117 thru C600	Not assigned						
C601	Capacitor: fixed, mica, 100 pf $\pm 10\%$ , 500 vdcw	00853	0140-0054	1	1		
C602	Capacitor: fixed, mica, 390 pf $\pm 10\%$ , 500 vdcw	76433	0140-0030	1	1		
C603	Same as C105						
C604	Capacitor: fixed, ceramic, 10 pf $\pm 0.5$ pf, 500 vdcw	96095	0150-0009	1	1		
J1 thru J100	Not assigned						
J101, 102	Connector, female: BNC	91737	1250-0047	2	1		
L1 thru L100	Not assigned						
L101, 102	Transformer, discriminator	28480	9130-0005	2	1		
L103	Coil: 19 $\mu$ h	28480	524B-60B	2	1		
L104 thru L600	Not assigned						
L601	Inductor: 25 $\mu$ h, wound on 10K resistor	28480	524B-60A	1	1		
L602	Same as L103						

\* See introduction to this section

Table 5-1. Replaceable Parts (Sheet 3 of 5)

Ckt Ref.	Description	Mfr *	Stock No.	TQ*	RS*		
L603	Inductor: 16 $\mu$ h, wound on 1 megohm resistor	28480	524B-60M	1	1		
L604	Inductor: 10.5 $\mu$ h, wound on 1 megohm resistor	28480	524B-60G	1	1		
P1 thru P100	Not assigned						
P101	Connector, male: 16 contact	02660	1251-0006	1	1		
P102	Connector, male: 8 contact	02660	1251-0008	1	1		
P103 thru P600	Not assigned						
P601	Connector, male: octal	02660	1251-0026	1	1		
R1 thru R100	Not assigned						
R101	Resistor: fixed, composition, 68,000 ohms $\pm 10\%$ , 1/2 W	01121	0687-6831	2	1		
R102	Resistor: fixed, composition, 130,000 ohms $\pm 5\%$ , 1/2 W	01121	0686-1345	2	1		
R103	Resistor: fixed, composition, 270,000 ohms $\pm 10\%$ , 1/2 W	01121	0687-2741	2	1		
R104	Resistor: fixed, composition, 560,000 ohms $\pm 10\%$ , 1/2 W	01121	0687-5641	2	1		
R105, 106	Resistor: fixed, composition, 33,000 ohms $\pm 10\%$ , 1/2 W	01121	0687-3331	4	1		
R107	Resistor: variable, composition, linear taper, 50,000 ohms $\pm 20\%$ , 1/3 W	71450	2100-0157	2	1		
R108	Resistor: fixed, composition, 120,000 ohms $\pm 10\%$ , 1/2 W Optimum value selected at factory Average value shown	01121	0687-1241	2	1		
R109	Resistor: fixed, composition, 150,000 ohms $\pm 10\%$ , 1/2 W	01121	0687-1541	2	1		
R110	Resistor: variable, composition, linear taper, 250,000 ohms $\pm 10\%$	01121	2100-0034	2	1		
R111	Resistor: fixed, composition, 2700 ohms $\pm 10\%$ , 1 W	01121	0690-2721	1	1		
R112	Same as R102						
R113	Same as R103						

\* See introduction to this section.



Table 5-1. Replaceable Parts (Sheet 4 of 5)

Ckt Ref.	Description	Mfr *	Stock No.	TQ*	RS*		
R114	Same as R104						
R115,116	Same as R105						
R117	Same as R101						
R118	Resistor: fixed, composition, 1000 ohms $\pm 10\%$ , 1 W	01121	0690-1021	1	1		
R119	Same as R107						
R120	Same as R108						
R121	Same as R109						
R122	Same as R110						
R123	Resistor: fixed, composition, 22,000 ohms $\pm 10\%$ , 1/2 W	01121	0687-2231	1	1		
R124 thru R601	Not assigned						
R602	Resistor: fixed, composition, 4700 ohms $\pm 10\%$ , 2 W	01121	0693-4721	2	1		
R603	Resistor: fixed, composition, 180,000 ohms $\pm 10\%$ , 1 W	01121	0690-1841	1	1		
R604	Resistor: fixed, composition, 82,000 ohms $\pm 10\%$ , 1/2 W	01121	0687-8231	1	1		
R605	Resistor: fixed, composition, 47,000 ohms $\pm 10\%$ , 1 W	01121	0690-4731	1	1		
R606	Not assigned						
R607	Resistor: fixed, composition, 1000 ohms $\pm 10\%$ , 1/2 W	01121	0687-1021	1	1		
R608,609	Resistor: fixed, composition, 8200 ohms $\pm 10\%$ , 2 W	01121	0693-8221	2	1		
R610	Resistor: fixed, composition, 200,000 ohms $\pm 5\%$ , 1 W	01121	0689-2045	1	1		
R611	Same as R602						
R612	Resistor: fixed, composition, 47,000 ohms $\pm 10\%$ , 1/2 W	01121	0687-4731	1	1		
R613,614	Resistor: fixed, composition, 3300 ohms $\pm 10\%$ , 2 W	01121	0693-3321	2	1		
R615	Resistor: fixed, deposited carbon, 90,000 ohms $\pm 1\%$ , 1/2 W	19701	0727-0203	2	1		

\* See introduction to this section

Table 5-1. Replaceable Parts (Sheet 5 of 5)

Ckt Ref.	Description	Mfr *	hp Stock No.	TQ*	RS*		
R616	Resistor: fixed, composition, 1500 ohms $\pm 10\%$ , 1 W	01121	0690-1521	1	1		
R617	Same as R615						
S1 thru S100	Not assigned						
S101	Trigger Level Switch Assembly: complete	28480	526B-19A	2	1		
	Switch, trigger level: less components	76854	3100-0088	1	0		
S102	Switch, toggle: SPST	04009	3101-0001	1	1		
S103	Same as S101						
S104	Switch, toggle: DPDT	04009	3101-0005	1	1		
S105, 106	Switch, toggle: SPDT	04009	3101-0002	2	1		
V1 thru V600	Not assigned						
V601	Tube, electron: 5963	80131	1932-0008	1	1		
V602,603	Tube, electron: 5654	80131	1923-0001	2	2		
	<u>MISCELLANEOUS</u>						
	Case, transit: for -hp- Model 526B	28480	525A-45A	1	0		
	Knob: TRIGGER LEVEL-VOLTS	28480	G-74H	4	0		
	Trigger Unit: complete	28480	526B-58B	2	1		
	Window, dial	28480	526B-99A	1	0		

\* See introduction to this section

## APPENDIX CODE LIST OF MANUFACTURERS (Sheet 1 of 2)

The following code numbers are from the Federal Supply Code for Manufacturers Cataloging Handbooks H4-1 (Name to Code) and H4-2 (Code to Name) and their latest supplements. The date of revision and the date of the supplements used appear at the bottom of each page. Alphabetical codes have been arbitrarily assigned to suppliers not appearing in the H4 handbooks.

CODE NO.	MANUFACTURER	ADDRESS	CODE NO.	MANUFACTURER	ADDRESS	CODE NO.	MANUFACTURER	ADDRESS
00334	Humidial Co.	Colton, Calif.	16758	Delco Radio Div. of G. M. Corp.	Kokomo, Ind.	71744	Chicago Miniature Lamp Works	Chicago, Ill.
00335	Westrex Corp.	New York, N.Y.	18873	E. I. DuPont and Co., Inc.	Wilmington, Del.	71753	A. O. Smith Corp., Crowley Div.	West Orange, N.J.
00373	Garlock Packing Co., Electronic Products Div.	Camden, N.J.	19315	Eclipse Pioneer, Div. of Bendix Aviation Corp.	Teterboro, N.J.	71785	Cinch Mfg. Corp.	Chicago, Ill.
00656	Aerovox Corp.	New Bedford, Mass.	19500	Thomas A. Edison Industries, Div. of McGraw-Edison Co.	West Orange, N.J.	71984	Dow Corning Corp.	Midland, Mich.
00781	Aircraft Radio Corp.	Boonton, N.J.	19701	Electra Manufacturing Co.	Kansas City, Mo.	72136	Electro Motive Mfg. Co., Inc.	Willimantic, Conn.
00853	Sangamo Electric Co., Cap. Div.	Marion, Ill.	20183	Electronic Tube Corp.	Philadelphia, Pa.	72619	Dialight Corp.	Brooklyn, N.Y.
00866	Goe Engineering Co.	Los Angeles, Calif.	21520	Fansteel Metallurgical Corp.	No. Chicago, Ill.	72656	General Ceramics Corp.	Keasbey, N.J.
00891	Carl E. Holmes Corp.	Los Angeles, Calif.	21335	The Fafnir Bearing Co.	New Britain, Conn.	72758	Girard-Hopkins	Oakland, Calif.
01121	Allen Bradley Co.	Milwaukee, Wis.	21964	Fed. Telephone and Radio Corp.	Clifton, N.J.	72765	Drake Mfg. Co.	Chicago, Ill.
01255	Litton Industries, Inc.	Beverly Hills, Calif.	24446	General Electric Co.	Schenectady, N.Y.	72825	Hugh H. Eby Inc.	Philadelphia, Pa.
01281	Pacific Semiconductors, Inc.	Culver City, Calif.	24455	G. E., Lamp Division	Nela Park, Cleveland, Ohio	72928	Gudeman Co.	Chicago, Ill.
01295	Texas Instruments, Inc., Semiconductor Components Div.	Dallas, Texas	24655	General Radio Co.	West Concord, Mass.	72982	Erie Resistor Corp.	Erie, Pa.
01349	The Alliance Mfg. Co.	Alliance, Ohio	26462	Grobet File Co. of America, Inc.	Carlstadt, N.J.	73061	Hansen Mfg. Co., Inc.	Princeton, Ind.
01561	Chassi-Trak Corp.	Indianapolis, Ind.	26992	Hamilton Watch Co.	Lancaster, Pa.	73138	Helipot Div. of Beckman Instruments, Inc.	Fullerton, Calif.
02114	Ferroxcube Corp. of America	Saugerties, N.Y.	28480	Hewlett-Packard Co.	Palo Alto, Calif.	73293	Hughes Products Div. of Hughes Aircraft Co.	Newport Beach, Calif.
02286	Cole Mfg. Co.	Palo Alto, Calif.	33173	G. E. Receiving Tube Dept.	Owensboro, Ky.	73445	Amperex Electronic Co., Div. of North American Phillips Co., Inc.	Hicksville, N.Y.
02660	Amphenol Electronics Corp.	Chicago, Ill.	35434	Lectrohm Inc.	Chicago, Ill.	73506	Bradley Semiconductor Corp.	New Haven, Conn.
02735	Radio Corp. of America Semiconductor and Materials Div.	Somerville, N.J.	37942	P. R. Mallory & Co., Inc.	Indianapolis, Ind.	73559	Carling Electric, Inc.	Hartford, Conn.
02777	Hopkins Engineering Co.	San Fernando, Calif.	39543	Mechanical Industries Prod. Co.	Akron, Ohio	73682	George K. Garrett Co., Inc.	Philadelphia, Pa.
03508	G.E. Semiconductor Products Dept.	Syracuse, N.Y.	40920	Miniature Precision Bearings, Inc.	Keene, N.H.	73743	Fischer Special Mfg. Co.	Cincinnati, Ohio
03705	Apex Machine & Tool Co.	Dayton, Ohio	42190	Muter Co.	Chicago, Ill.	73793	The General Industries Co.	Elyria, Ohio
03797	Eldema Corp.	El Monte, Calif.	44655	Ohmite Mfg. Co.	Skokie, Ill.	73905	Jennings Radio Mfg. Co.	San Jose, Calif.
04009	Arrow, Hart and Hegeman Elect. Co.	Hartford, Conn.	48620	Precision Thermometer and Inst. Co.	Philadelphia, Pa.	74455	J. H. Winns, and Sons	Winchester, Mass.
04062	Elmenco Products Co.	New York, N.Y.	49956	Raytheon Mfg. Co.	Waltham, Mass.	74861	Industrial Condenser Corp.	Chicago, Ill.
04222	Hi-Q Division of Aerovox	Myrtle Beach, S.C.	54294	Shallcross Mfg. Co.	Selma, N.C.	74868	Industrial Products Co.	Danbury, Conn.
04404	Dymec Inc.	Palo Alto, Calif.	55026	Simpson Electric Co.	Chicago, Ill.	74970	E. F. Johnson Co.	Waseca, Minn.
04651	Special Tube Operations of Sylvania Electronic Systems	Mountain View, Calif.	55933	Sonotone Corp.	Elmsford, N.Y.	75042	International Resistance Co.	Philadelphia, Pa.
04713	Motorola, Inc., Semiconductor Prod. Div.	Phoenix, Arizona	55938	Sorenson & Co., Inc.	So. Norwalk, Conn.	75173	Jones, Howard B., Division of Cinch Mfg. Corp.	Chicago, Ill.
04777	Automatic Electric Sales Corp.	Northlake, Ill.	56137	Spaulding Fibre Co., Inc.	Tonawanda, N.Y.	75378	James Knights Co.	Sarjwich, Ill.
05624	Barber Colman Co.	Rockford, Ill.	56289	Sprague Electric Co.	North Adams, Mass.	75382	Kulka Electric Mfg. Co., Inc.	Mt. Vernon, N.Y.
05783	Stewart Engineering Co.	Soquel, Calif.	61775	Union Switch and Signal, Div. of Westinghouse Air Brake Co.	Pittsburgh, Pa.	75818	Lenz Electric Mfg. Co.	Chicago, Ill.
06004	The Bassick Co.	Bridgport, Conn.	62119	Universal Electric Co.	Owosso, Mich.	75915	Littelfuse Inc.	Des Plaines, Ill.
06812	Torrington Mfg. Co., West. Div.	Van Nuys, Calif.	64959	Western Electric Co., Inc.	New York, N.Y.	76005	Lord Mfg. Co.	Erie, Pa.
07115	Corning Glass Works Electronic Components Dept.	Bradford, Pa.	65092	Weston Inst. Div. of Daystrom, Inc.	Newark, N.J.	76210	C. W. Marwedel	San Francisco, Calif.
07261	Avnet Corp.	Los Angeles, Calif.	70119	Advance Electric and Relay Co.	Burbank, Calif.	76433	Micamold Electronic Mfg. Corp.	Brooklyn, N.Y.
07263	Fairchild Semiconductor Corp.	Mountain View, Calif.	70276	Allen Mfg. Co.	Hartford, Conn.	76487	James Millen Mfg. Co., Inc.	Malden, Mass.
07933	Rheem Semiconductor Corp.	Mountain View, Calif.	70309	Allied Control Co., Inc.	New York, N.Y.	76530	Monadnock Mills	San Leandro, Calif.
07980	Boonton Radio Corp.	Boonton, N.J.	70563	Amperite Co., Inc.	New York, N.Y.	76545	Mueller Electric Co.	Cleveland, Ohio
08718	Cannon Electric Co. Phoenix Div.	Phoenix, Ariz.	70903	Belden Mfg. Co.	Chicago, Ill.	76854	Oak Manufacturing Co.	Chicago, Ill.
08733	Camloc Fastener Corp.	Los Angeles, Calif.	70998	Bird Electronic Corp.	Cleveland, Ohio	77068	Bendix Corp., Bendix Pacific Div.	No. Hollywood, Calif.
08792	CBS Electronics Semiconductor Operations, Div. of C.B.S. Inc.	Lowell, Mass.	71002	Birnbach Radio Co.	New York, N.Y.	77221	Phaotron Instrument and Electronic Co.	South Pasadena, Calif.
09134	Texas Capacitor Co.	Houston, Texas	71218	Bud Radio Inc.	Cleveland, Ohio	77342	Potter and Brumfield, Inc.	Princeton, Ind.
09250	Electro Assemblies, Inc.	Chicago, Ill.	71286	Camloc Fastener Corp.	Paramus, N.J.	77630	Radio Condenser Co.	Camden, N.J.
10646	Carborundum Co.	Niagara Falls, N.Y.	71313	Allen D. Cardwell Electronic Prod. Corp.	Plainville, Conn.	77634	Radio Essentials Inc.	Mt. Vernon, N.Y.
12697	Clarostat Mfg. Co.	Dover, N.H.	71400	Bussmann Fuse Div. of McGraw- Edison Co.	St. Louis, Mo.	77638	Radio Receptor Co., Inc.	Brooklyn, N.Y.
14655	Cornell Dubilier Elec. Corp.	So. Plainfield, N.J.	71450	Chicago Telephone Supply Co.	Elkhart, Ind.	77764	Resistance Products Co.	Harrisburg, Pa.
15909	The Daven Co.	Livingston, N.J.	71468	Cannon Electric Co.	Los Angeles, Calif.	78283	Signal Indicator Corp.	New York, N.Y.
			71471	Cinema Engineering Co.	Burbank, Calif.	78471	Tilley Mfg. Co.	San Francisco, Calif.
			71482	C. P. Clare & Co.	Chicago, Ill.	78488	Stackpole Carbon Co.	St. Marys, Pa.
			71590	Centralab Div. of Globe Union Inc.	Milwaukee, Wis.	79142	Veeder Root, Inc.	Hartford, Conn.
			71700	The Cornish Wire Co.	New York, N.Y.	79251	Wenco Mfg. Co.	Chicago, Ill.
						79963	Zierick Mfg. Corp.	New Rochelle, N.Y.
						80130	Times Facsimile Corp.	New York, N.Y.

From: F.S.C. Handbook Supplements  
H4-1 Dated July 1960  
H4-2 Dated July 1960

00015-2  
Revised: 31 Jan. 1961

**APPENDIX CODE LIST OF MANUFACTURERS (Sheet 2 of 2)**

CODE NO.	MANUFACTURER	ADDRESS	CODE NO.	MANUFACTURER	ADDRESS	CODE NO.	MANUFACTURER	ADDRESS
80131	Electronic Industries Association Any brand tube meeting EIA standards	Washington, D.C.	89473	General Electric Distributing Corp.	Schenectady, N.Y.	98405	Carad Corp.	Redwood City, Calif.
80248	Oxford Electric Corp.	Chicago, Ill.	90179	U.S. Rubber Co., Mechanical Goods Div.	Passaic, N.J.	98734	Palo Alto Engineering Co., Inc.	Palo Alto, Calif.
80411	Acro Manufacturing Co.	Columbus, Ohio	90970	Bearing Engineering Co.	San Francisco, Calif.	98925	Clevite Transistor Prod. Div. of Clevite Corp.	Waltham, Mass.
80486	All Star Products Inc.	Defiance, Ohio	91418	Radio Materials Co.	Chicago, Ill.	99109	Columbia Technical Corp.	New York, N.Y.
80583	Hammerlund Co., Inc.	New York, N.Y.	91506	Augat Brothers, Inc.	Attleboro, Mass.	99313	Varian Associates	Palo Alto, Calif.
80640	Stevens, Arnold, Co., Inc.	Boston, Mass.	91637	Dale Products, Inc.	Columbus, Neb.	99800	Delevan Electronics Corp.	East Aurora, N.Y.
81030	International Instruments, Inc.	New Haven, Conn.	91662	Elco Corp.	Philadelphia, Pa.	99821	North Hills Electric Co.	Great Neck, L.I., N.Y.
81415	Wilkor Products, Inc.	Cleveland, Ohio	91737	Gremar Mfg. Co., Inc.	Wakefield, Mass.	99848	Wilco Corporation	Indianapolis, Ind.
81453	Raytheon Mfg. Co., Industrial Tube Division	Quincy, Mass.	91929	Micro-Switch Div. of Minneapolis Honeywell Regulator Co.	Freeport, Ill.	99934	Renbrandt, Inc.	Boston, Mass.
81483	International Rectifier Corp.	El Segundo, Calif.	92196	Universal Metal Products, Inc.	Bassett Puente, Calif.	99942	Hoffman Semiconductor Div. of Hoffman Electronics, Corp.	Evanston, Ill.
82042	Carter Parts Co.	Skokie, Ill.	93332	Sylvania Electric Prod. Inc., Semiconductor Div.	Woburn, Mass.	99957	Technology Instruments Corp. of Calif.	No. Hollywood, Calif.
82170	Allen B. DuMont Labs., Inc.	Clifton, N.J.	93410	Stevens Mfg. Co., Inc.	Mansfield, Ohio			
82209	Maguire Industries, Inc.	Greenwich, Conn.	93983	Insuline-Van Norman Ind., Inc. Electronic Division	Manchester, N.H.			
82219	Sylvania Electric Prod. Inc., Electronic Tube Div.	Emporium, Pa.	94144	Raytheon Mfg. Co., Receiving Tube Div.	Quincy, Mass.			
82376	Astron Co.	East Newark, N.J.	94145	Raytheon Mfg. Co., Semi- conductor Div.	Newton, Mass.			
82389	Switchcraft, Inc.	Chicago, Ill.	94154	Tung-Sol Electric, Inc.	Newark, N.J.			
82647	Spencer Thermostat, Div. of Texas Instruments, Inc.	Attleboro, Mass.	94197	Curtiss-Wright Corp., Electronics Div.	Carlstadt, N.J.			
82866	Research Products Corp.	Madison, Wis.	94310	Tru Ohm Prod. Div. of Model Engineering and Mfg. Co.	Chicago, Ill.			
82893	Vector Electronic Co.	Glendale, Calif.	95236	Allies Products Corp.	Miami, Fla.			
83148	Electro Cords Co.	Los Angeles, Calif.	95238	Continental Connector Corp.	Woodside, N.Y.			
83186	Victory Engineering Corp.	Union, N.J.	95263	Leecraft Mfg. Co., Inc.	New York, N.Y.			
83298	Bendix Corp., Red Bank Div.	Red Bank, N.J.	95265	National Coil Co.	Sheridan, Wyo.			
83594	Burroughs Corp., Electronic Tube Div.	Plainfield, N.J.	95987	Weckesser Co.	Chicago, Ill.			
83777	Model Eng. and Mfg., Inc.	Huntington, Ind.	96067	Huggins Laboratories	Sunnyvale, Calif.			
83821	Loyd Scruggs Co.	Festus, Mo.	96095	Hi-Q Division of Aerovox	Olean, N.Y.			
84171	Arco Electronics, Inc.	New York, N.Y.	96296	Solar Manufacturing Co.	Los Angeles, Calif.			
84396	A. J. Glesener Co., Inc.	San Francisco, Calif.	96341	Microwave Associates, Inc.	Burlington, Mass.			
84411	Good All Electric Mfg. Co.	Ogallala, Neb.	96501	Excel Transformer Co.	Oakland, Calif.			
84970	Sarkes Tarzian, Inc.	Bloomington, Ind.	97539	Automatic and Precision Mfg. Co.	Yonkers, N.Y.			
85474	R. M. Bracamonte & Co.	San Francisco, Calif.	97966	CBS Electronics, Div. of C.B.S., Inc.	Danvers, Mass.			
85660	Koiled Kords, Inc.	New Haven, Conn.	98141	Axel Brothers Inc.	Jamaica, N.Y.			
86684	Radio Corp. of America, RCA Electron Tube Div.	Harrison, N.J.	98220	Francis L. Mosley	Pasadena, Calif.			
88140	Cutler-Hammer, Inc.	Lincoln, Ill.	98278	Microdot, Inc.	So. Pasadena, Calif.			
			98291	Sealectro Corp.	New Rochelle, N.Y.			

THE FOLLOWING H.P VENDORS HAVE NO NUMBER ASSIGNED IN THE LATEST SUPPLEMENT TO THE FEDERAL SUPPLY CODE FOR MANUFACTURERS HANDBOOK.

0000A	Amp, Inc.	Hawthorne, Calif.
0000B	Chicago Telephone of Calif.	S. Pasadena, Calif.
0000C	Connor Spring Mfg. Co.	San Francisco, Calif.
0000D	Connex Corp.	Oakland, Calif.
0000E	Fisher Switches, Inc.	San Francisco, Calif.
0000F	Malco Tool and Die	Los Angeles, Calif.
0000G	Microwave Engineering Co.	Palo Alto, Calif.
0000H	Philco Corp. (Lansdale Tube Division)	Lansdale, Pa.
0000I	Telefunken (c/o American Elite)	New York, N.Y.
0000J	Ti Tal, Inc.	Berkeley, Calif.
0000K	Transitron Electronic Sales Corp.	Wakefield, Mass.
0000L	Winchester Electronics, Inc.	Santa Monica, Calif.
0000M	Western Coil Div. of Automatic Ind., Inc.	Redwood City, Calif.
0000N	Nahm-Bros. Spring Co.	San Leandro, Calif.
0000P	Ty-Car Mfg. Co., Inc.	Holliston, Mass.
0000R	Metro Cap. Div., Metropolitan Telecommunications Corp.	Brooklyn, N.Y.

00015-2  
Revised: 31 Jan. 1961

From: F.S.C. Handbook Supplements  
H4-1 Dated July 1960  
H4-2 Dated July 1960

# hp MANUAL CHANGES

MODEL 526B

TIME INTERVAL UNIT

Manual Serial Prefixed: 024-  
Manual Printed: 3/61

To adapt this manual to instruments with other serial prefixes check for errata below, and make changes shown in tables.

Instrument Serial Prefix	Make Manual Changes	Instrument Serial Number	Make Manual Changes
024-	ERRATA	024-04249	1

## CLAIM FOR DAMAGE IN SHIPMENT

**ERRATA:** Table of Replaceable Parts, under MISCELLANEOUS:  
Delete Ⓢ Stock No. G-74H and add:  
Knob, with dial: TRIGGER LEVEL-VOLTS, coarse; Ⓢ Stock No. 526B-40C.  
Knob, with dial: TRIGGER LEVEL-VOLTS, fine; Ⓢ Stock No. 526B-40D.

Under SPECIFICATIONS,  
ACCESSORIES FURNISHED: Change to read: "Ⓢ AC-16K Cable Assembly. 42" RG-58/U cable terminated on both ends with UG-88/U BNC connectors."

Figure 4-2  
Stop-Trigger Unit should be Start-Trigger Unit.  
Start-Trigger Unit should be Stop-Trigger Unit.

---

CHANGE 1 Table of Replaceable Parts,  
J101, 102: Change Ⓢ Stock No. to 1250-0118.

8/21/62 - (2-1030)

5/24/62

